Electric Rocket Engine System R&D

In PROITERES, a powered flight by an electric rocket engine is planned; that is, orbital transfer will be carried out with a pulsed plasma thruster (PPT). We introduce the research and development of PPTs at Osaka Institute of Technology.

1. Pulsed Plasma Thruster

Pulsed plasma thrusters (PPTs) are expected to be used as a thruster for a small satellite. The PPT has some features superior to other kinds of electric propulsion. It has no sealing part, simple structure and high reliability, which are benefits of using a solid propellant, mainly Teflon[®] (poly-tetrafluoroethylene: PTFE). However, performances of PPTs are generally low compared with other electric thrusters.

At Osaka Institute of Technology, the PPT has been studied in order to understand physical phenomena and improve thrust performances with both experiments and numerical simulations. We mainly studied electrothermal-acceleration-type PPTs, which generally had higher thrust-to-power ratios (impulse bit per unit initial energy stored in capacitors) and higher thrust efficiencies than electromagnetic-acceleration-type PPTs. Although the electrothermal PPT has lower specific impulse than the electromagnetic PPT, the low specific impulse is not a significant problem as long as the PPT uses solid propellant, because there is no tank nor valve for liquid or gas which would be a large weight proportion of a thruster system.

This article mainly presents studies on the recent R&D of the electrothermal PPT onboard PROITERES satellite.

2. Thrust Measurement System for Ground-Based Experiments

Figure 1 shows a thrust stand in a vacuum chamber for precise measurement of an impulse bit. The PPT and capacitors are mounted on the pendulum, which rotates around fulcrums of two knife edges without friction. The displacement of the pendulum is detected by an eddy-current-type gap sensor (non-contacting micro-displacement meter) near the PPT, which resolution is about $\pm 0.5 \mu\text{m}$. The electromagnetic damper is used to suppress mechanical noises and to decrease quickly the amplitude for the next measurement after firing the PPT. It is useful for a sensitive thrust stand because it is non-contacting. The damper

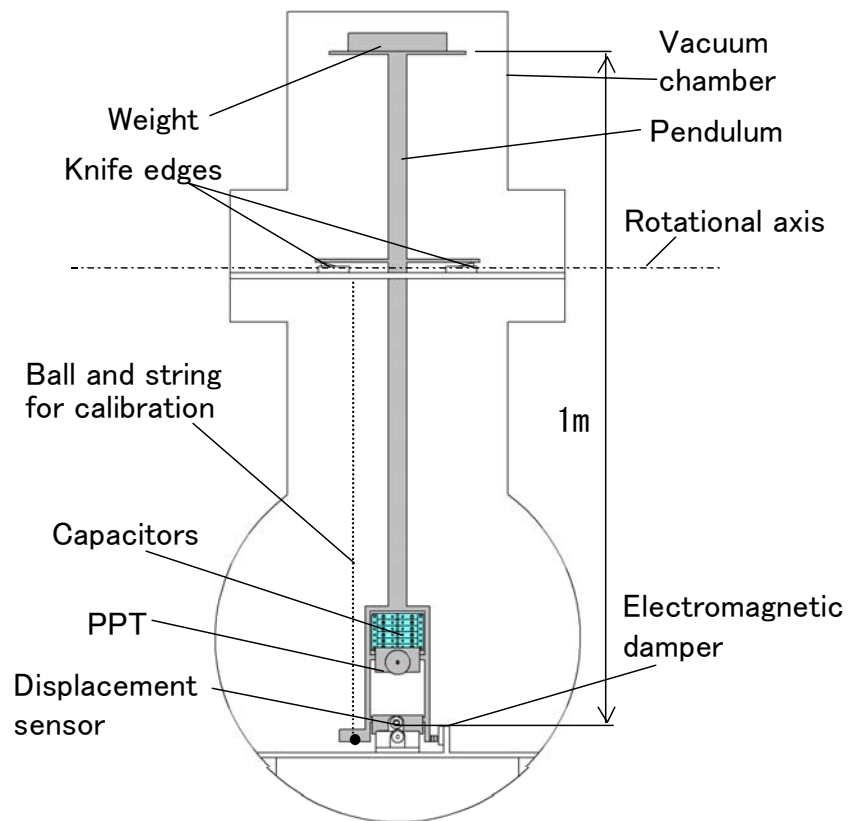

Fig.1 Large vacuum chamber and thrust stand.

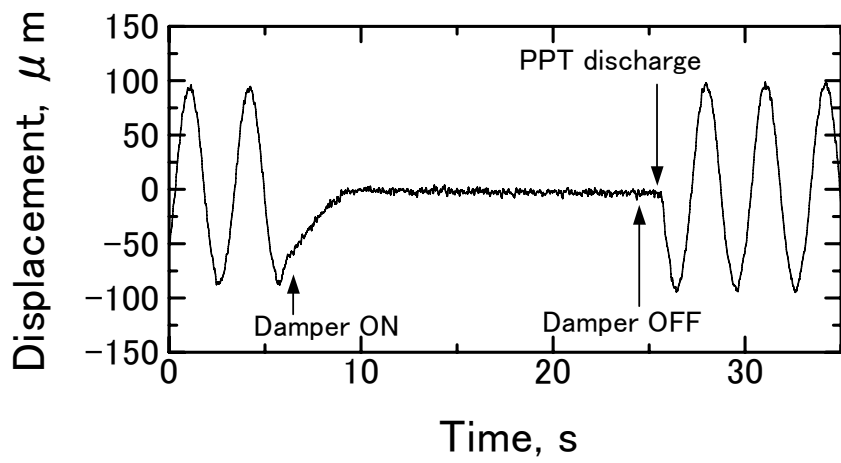

Fig.2 Typical signal of displacement in measurement of impulse bit.

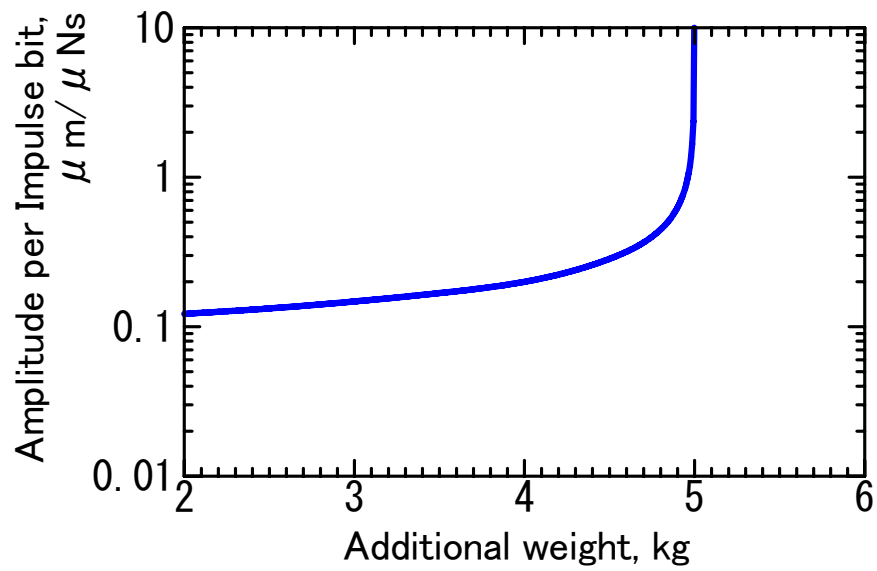

Fig.3 Sensitiveness of thrust stand vs top weight.

consists of a permanent magnet fixed to the pendulum and two coils fixed to the supporting stand. The control circuit differentiates the output voltage of the displacement sensor and supplies the current proportional to the differentiated voltage to the coil. Accordingly, the damper works as a viscosity resistor. The damper is turned off just before firing the PPT for measurements without damping, and turned on after the measurement to prepare for the next measurement. Figure 2 shows a typical signal of displacement in measurement of impulse bit. Sensitiveness of the thrust stand is variable by changing the weight mounted on the top of the pendulum as shown in Fig.3. A calibration of the thrust stand is carried out by collisions of balls to the pendulum with various balls from various distances corresponding 15-1400 μNs .

3. Electrothermal PPT with Side-Fed-Type Propellant Feeding Mechanism

Figure 4 shows a PPT with a propellant feeding mechanism designed considering the results of a preliminary PPT. A cavity is formed between two PTFE bars of 6 mm in thickness and two Pyrex[®] glass bars of 5 mm in thickness. The cross-sectional area of the cavity (6.5 mm^2) is a little smaller than that of the preliminary model (7.1 mm^2). The cavity length is 12 mm. The PTFE bars are provided due to spring loads of approximately 3 N. The glass bars are fixed to the body. The anode and the cathode are made of tungsten and stainless steel, respectively. Main discharge is initiated by an igniter mounted in the cathode nozzle. The nozzle has a length of 28 mm and a half angle of 30 degree.

The PPT showed initial performances of impulse bit per unit stored energy (thrust-to-power ratio) of 43-48 $\mu\text{Ns}/\text{J}$ ($\mu\text{N}/\text{W}$), specific impulse of 470-500 s and thrust efficiency of 11-12 % as shown in Fig.5. It is remarkable that performance is kept high even at the low energy of 4.5 J.

In order to investigate physical phenomena in the discharge system including plasma, an unsteady numerical simulation was carried out. Figure 6 shows the calculation model. The calculation simultaneously simulates unsteady phenomena of discharge in the circuit, heat transfer to the PTFE, heat conduction inside the PTFE, ablation from the PTFE surface and plasma flow. As shown in Fig.7, ablation from the PTFE surface begins at approximately 2 μs with decreasing the plasma temperature, and it is completed by 6 μs . After the ablation, gas starts to be exhausted due to the gradient of pressure, and the thrust is generated until over 25 μs . Then, most of impulse is generated by exhausted neutral gas.

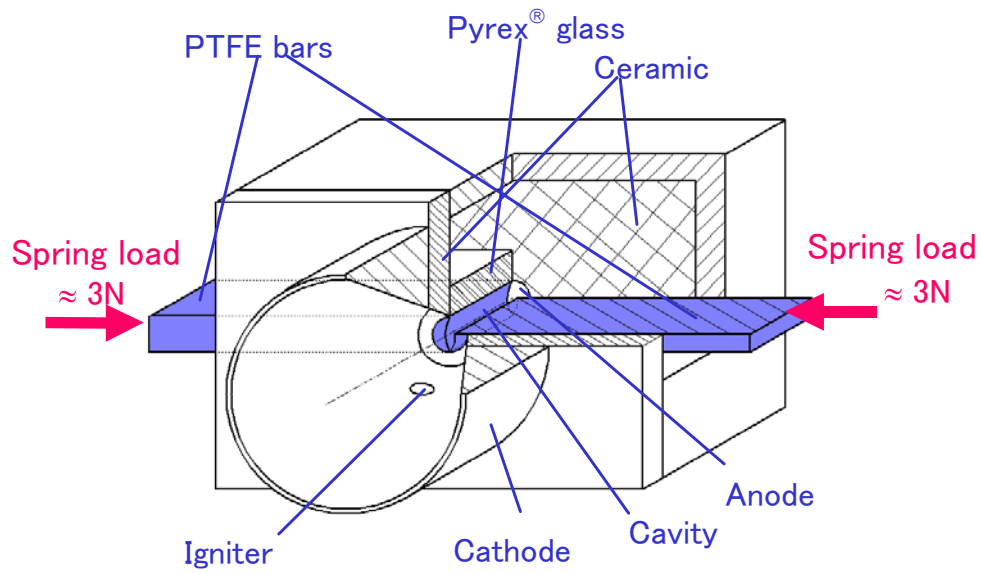

a)

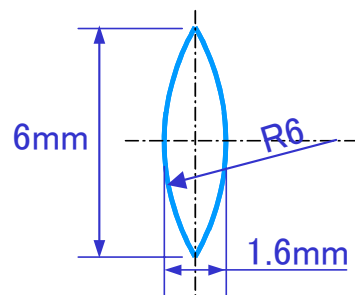

b)

Fig.4 Electrothermal pulsed plasma thruster with a propellant feeding mechanism: a) thruster and b) cross section of cavity.

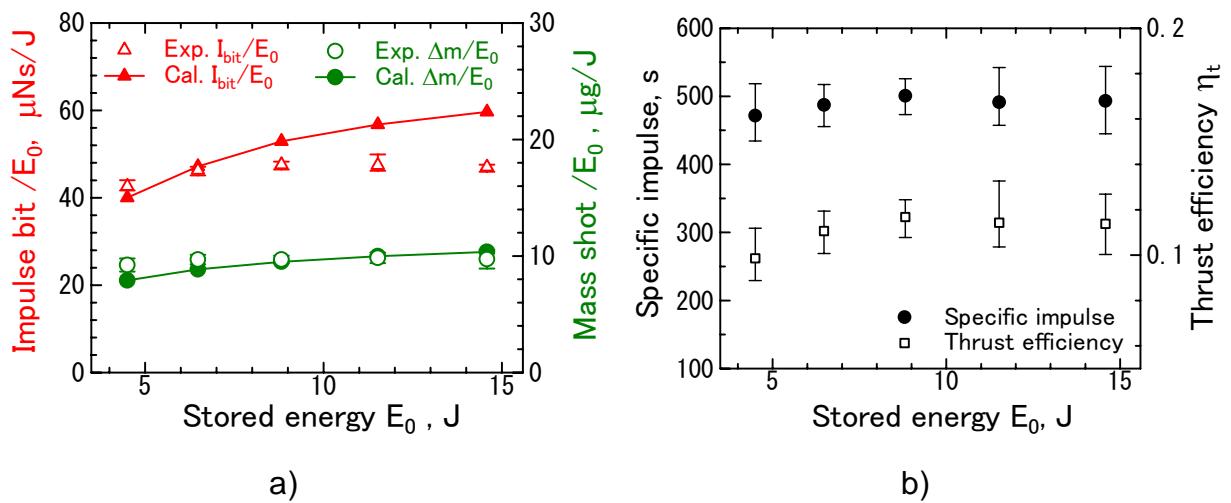
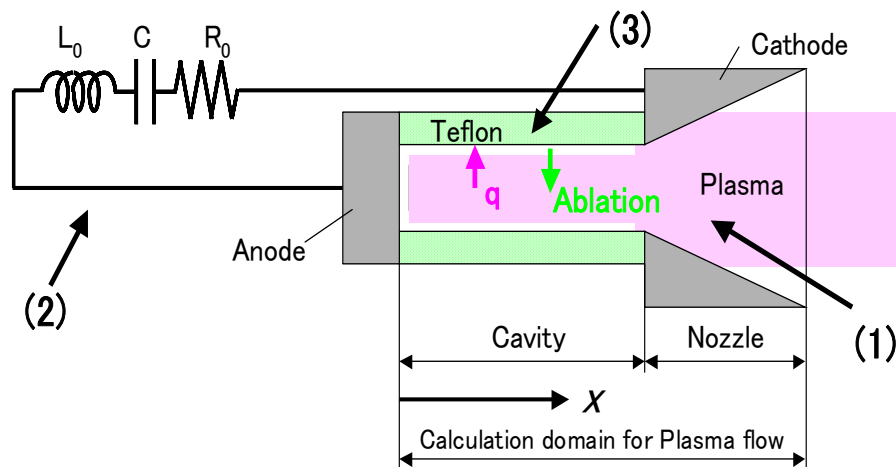

Fig.5 Initial performance vs stored energy: a) experimental and calculated impulse bit and mass shot per unit stored energy, and b) measured specific impulse and thrust efficiency.



This model consists of :

- (1) Plasma fluid
- (2) Discharge circuit (LCR circuit)

$$L_0 \ddot{Q} + (R_0 + R_p) \dot{Q} + Q/C = 0$$
- (3) Heat transfer to/inside Teflon

Assumptions :

- ◆ LTE ($T_e = T_i = T_n$)
- ◆ Ionization equilibrium
- ◆ Plasma flow: One-fluid
- ◆ Magnetic field is neglected

Fig.6 Calculation model for PPT system.

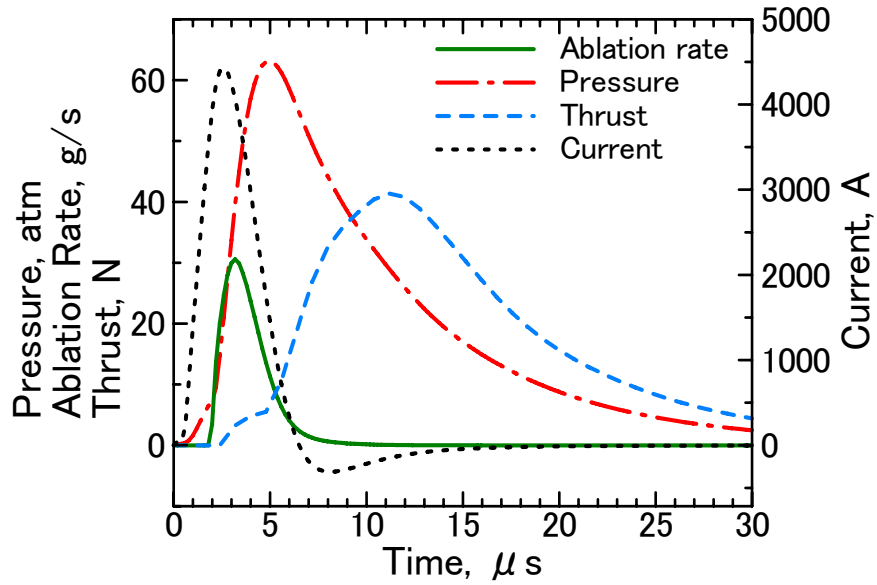

Fig.7 Calculated time variations of properties for electrothermal PPT.

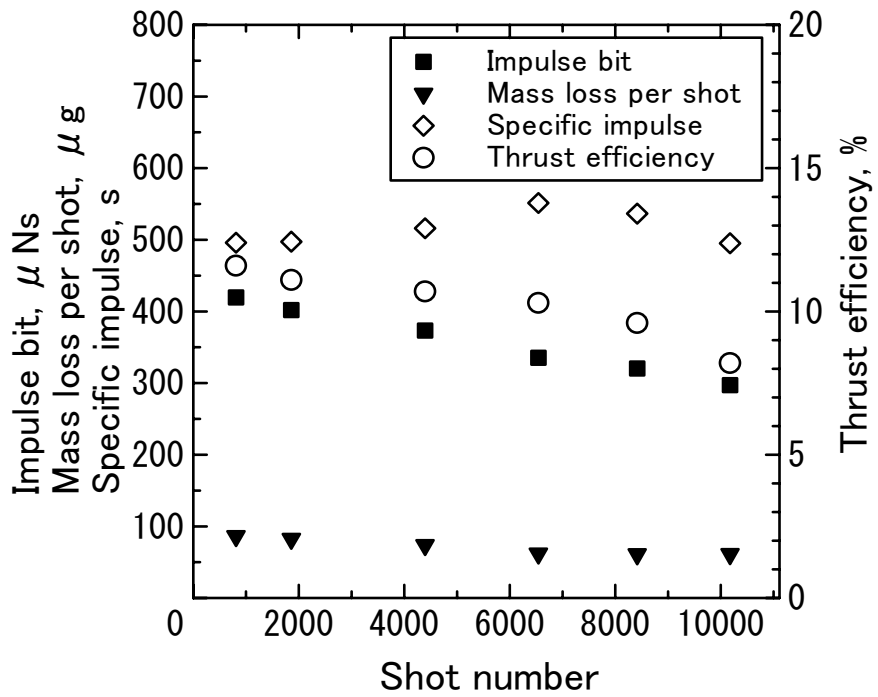

Fig.8 Result of repetitive 10000-shot test ($E_0=8.8$ J).

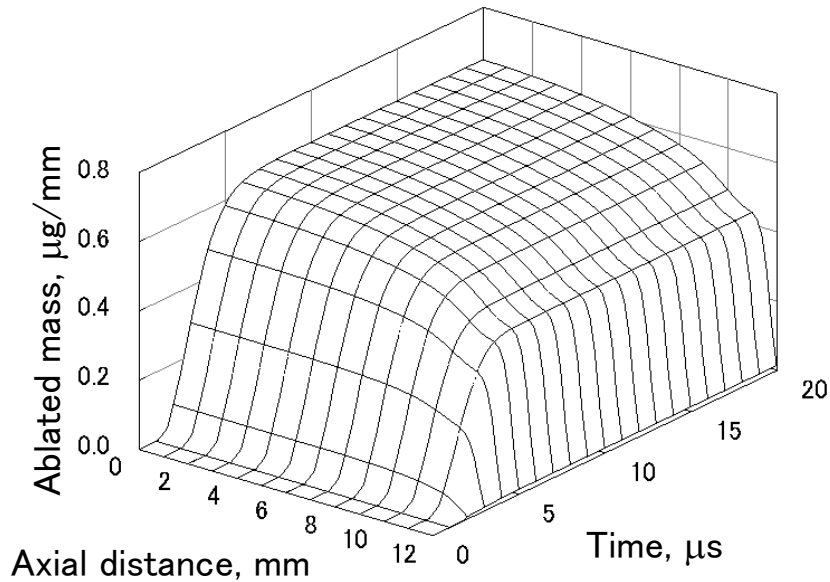

Fig.9 Calculated time and spatial distribution of ablated mass per unit area ($E_0=8.8$ J).

Mass shots calculated by an unsteady numerical simulation show excellent agreements with the experimental results. Therefore, it is considered that phenomena in the cavity (generation of plasma, heat supply to the PTFE, and ablation) and the discharge circuit are well simulated with this model. The calculated impulse bits are somewhat larger than the experimental results. Other neglected factors lowering the impulse bit should be considered in a future study, e.g., flow separation from the nozzle surface.

A calculated result showed the existence of considerable amount of ablation delaying to the discharge. However, it was also shown that this phenomenon should not be regarded as the late time ablation (LTA) for electrothermal PPTs because the neutral gas ablated delaying to the discharge generated most of total pressure and impulse bit.

A 10000-shot operation was conducted at a frequency of 0.5 Hz with a stored energy of 8.8 J corresponding to a power of 4.4 W. Figure 8 shows changes in performances during the test. Both the impulse bit and the thrust

efficiency decrease gradually because of uneven receding of PTFE surface. Figure 9 shows a calculated time and spatial distribution of ablated mass per unit area. The uneven surface of the propellant depends on the axial distribution of plasma density in the cavity. In spite of the uneven ablation on the surface, each PTFE bar of approximately 2 mm was used and supplied by the propellant feeding mechanism, and a total impulse of 3.6 Ns was obtained.

4. Low-Power Electrothermal PPT onboard PROITERES

Considering the R&D of electrothermal PPTs with side-fed-type propellant feeding mechanism in the above Section 3, we developed a low-power electrothermal PPT for PROITERES satellite. The input energy is about 2.5 J. Figures 10 and 11 show the photograph of the PPT designed for PROITERES. This PPT has a small cavity diameter of 1.0 mm. The performance is examined changing cavity length. The measured history of impulse bit vs shot number is shown in Fig.12. The highest total impulse of 1.6 Ns after 10000 shots was obtained with 9.0 mm. We fixed a cavity length to 9.0 mm for the satellite.

The power processing unit (PPU) and the capacitor for the PPTs onboard PROITERES are shown in Fig.13. The PPU can operate simultaneously two PPTs with each one capacitor. In PROITERES, the one PPU, two capacitors and four PPTs will be amounted, and each two PPTs are operated simultaneously.



Fig.10 Photo of electrothermal PPT onboard PROITERES.



Fig.11 Photo of exhaust plasma plume.

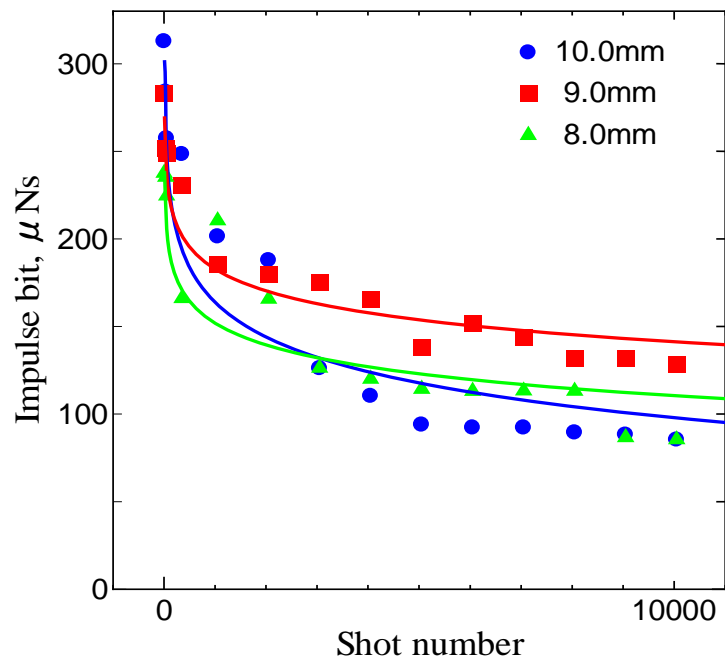

Fig.12 Impulse bit vs shot number dependent on cavity length.

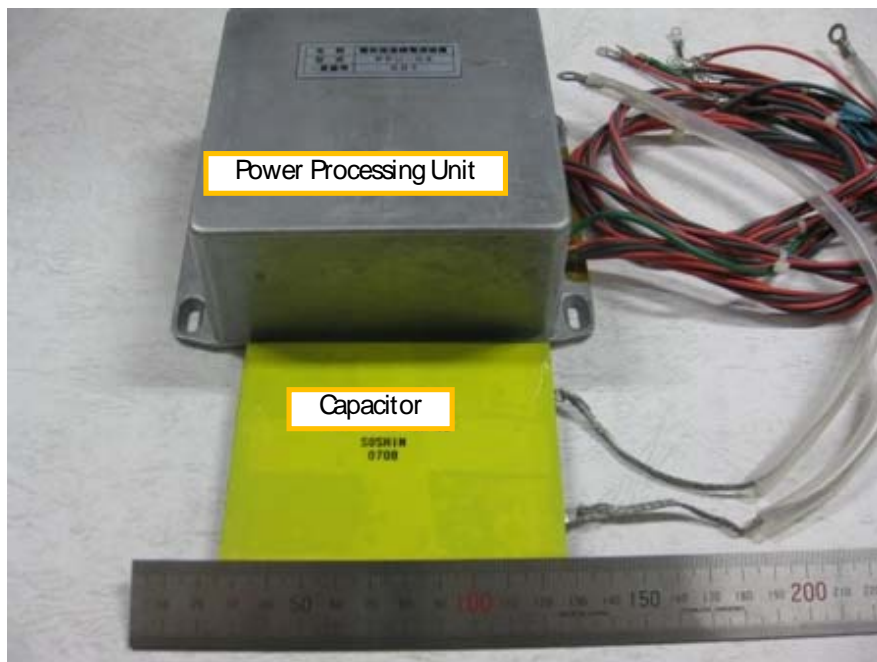

Fig.13 PPU and capacitor for PPTs onboard PROITERES.